

DC Charging Station ET-EV03-120/180/240

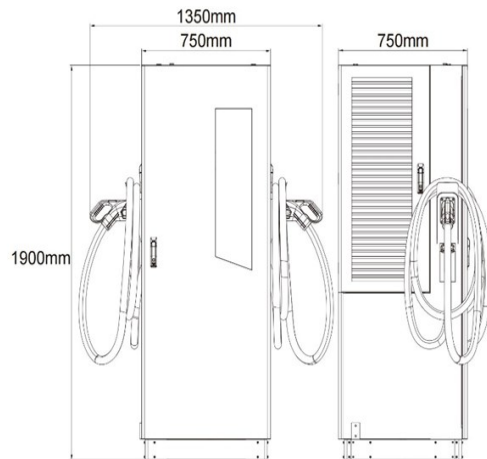

Product dimension



High efficiency

High power DC output, the maximum power is optional 240kW, which can improve charging efficiency and alleviate users' anxiety when charging. one charger with two plugs, intelligent distribution of single and double plugs in different scenarios of power output, full use of each kilowatt to reduce waste.



Excellent adaptability

Strong adaptability to the environment: it can be installed outdoors and indoors. High car charging compatibility: 150-1000V voltage output of different levels, to meet the needs of different types of vehicles.



Intelligent control

Quipped with international general OCPP-1.6 communication protocol, which can be connected to the user's backstage management platform. It can swipe by RFID to charge and calculate charging cost to provide commercial functions for users. Touch-screen control provides convenience for maintenance personnel. Bluetooth/wi-fi/Ethernet / 4G a variety of communication methods available for selection.



All-round security protection

Provide users with safe charging experience, we have voltage, current, temperature, grounding, lightning, leakage protection and other electrical protection, to ensure the normal use of users. The product has the IK10 protection grade, and passes the strict safety test before leaving the factory to ensure the safety performance of each product.

Specification

	Model	ET-EV03-120/180/240
Power Input	Input Type	3-Phase
	Input Wiring Scheme	3P+N+PE
	Rated Voltage	400VAC ± 15%
	Max. THDi	5%
	Min. Power Factor	0.98
Power Output	Grid Frequency	50Hz or 60Hz
	Output Voltage	150-1000VDC
	Maximum Current	200A
	Rated Power	60-240kW
User Interface	Number of Connectors	1 or 2
	Charge Connector	CCS2 Plug(CCS1 Plug Optional)
	LED Indicator	Green/Blue/Red,Progress Indicator
	LCD Display	7 Inch Touch Color Screen
	RFID Reader	ISO/IEC 14443 RFID Card Reader
Communication	Start Mode	RFID Card or APP
	Backend	Ethernet,Optional: Cellular/W-iFi/Bluetooth
	Charging protocol	OCPP-1.6J
	Energy Metering	Meter With 1% Accuracy
Safety and Certification	Residual Current Device	Yes
	Internal FUSE	Yes
	Ingress Protection	IP54
	Impact Protection	IK10
	Cooling method	Fan Cooling
	Max. Operating Noise Level	65dB
	Electrical Protection	Over/Under Voltage Protection,Over Current Protection, Short Circuit Protection, Over/Under Temperature Protection,Lightning Protection,Ground Protection
	Certification	CE,TUV(coming soon)
Environment	Certification and Conformity	IEC62196-1/-3,IEC 61851-1/-23/-24
	Mounting	Free-standing Cabinet
	Storage Temperature	-40°C - +75°C
	Operating Temperature	-30°C - +55°C
	Max. Operating Humidity	95%, Non-condensing
Mechanical	Max. operating altitude	2000m
	Product Dimension	750mm*750mm*1900mm(W*D*H)
	Package Dimension	1000mm*920mm*2100mm(W*D*H)
	Weight	257-366kg(Net)/276-386kg(Gross)